



# SKV AUTOMOTIVE PVT LTD



[info@skvauto.com](mailto:info@skvauto.com)

[www.skvauto.com](http://www.skvauto.com)

+0120-4091339

# ABOUT US

## WE THRIVE TO DELIVER

**SKV Automotive (Formerly National Engineering Works)** manufactures a wide range of high quality, precision engineered automotive & sheet metal parts. With over three decades of production expertise, the company is a well known name in North India in sheet metal components & friction products like brake pads backplates, unlined brake shoes & levers. A high degree of quality control and the ability to stay in step with changing global requirements have ensured that the company is associated with quality and reliability for its customers.

**2004**

Year Founded

**100+**

Total Employees

**1M+**

Production Capacity

**A+**

Client Ratings

# MANAGEMENT VISION

## ADAPTIVE & COMPETITIVE

The 21st century demands companies and products of high quality only. We are committed to meet these challenges through our business strategy of providing a quality product at cost competitive prices. We believe that our customers, our employees and our vendors are all part of our family.



# OUR MEMBERS

## THE TEAM BEHIND OUR SUCCESS

**Mr. Raghumani Buddala**

CEO | Director

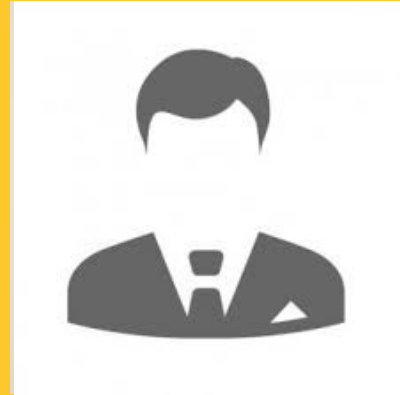

**Mr. Buddala Dasarathi**

Director

**Mr. Abhijeet M.**

General Manager (Operations)



# OUR ORGANISATION

## WE IDENTIFY AS SKVIAN

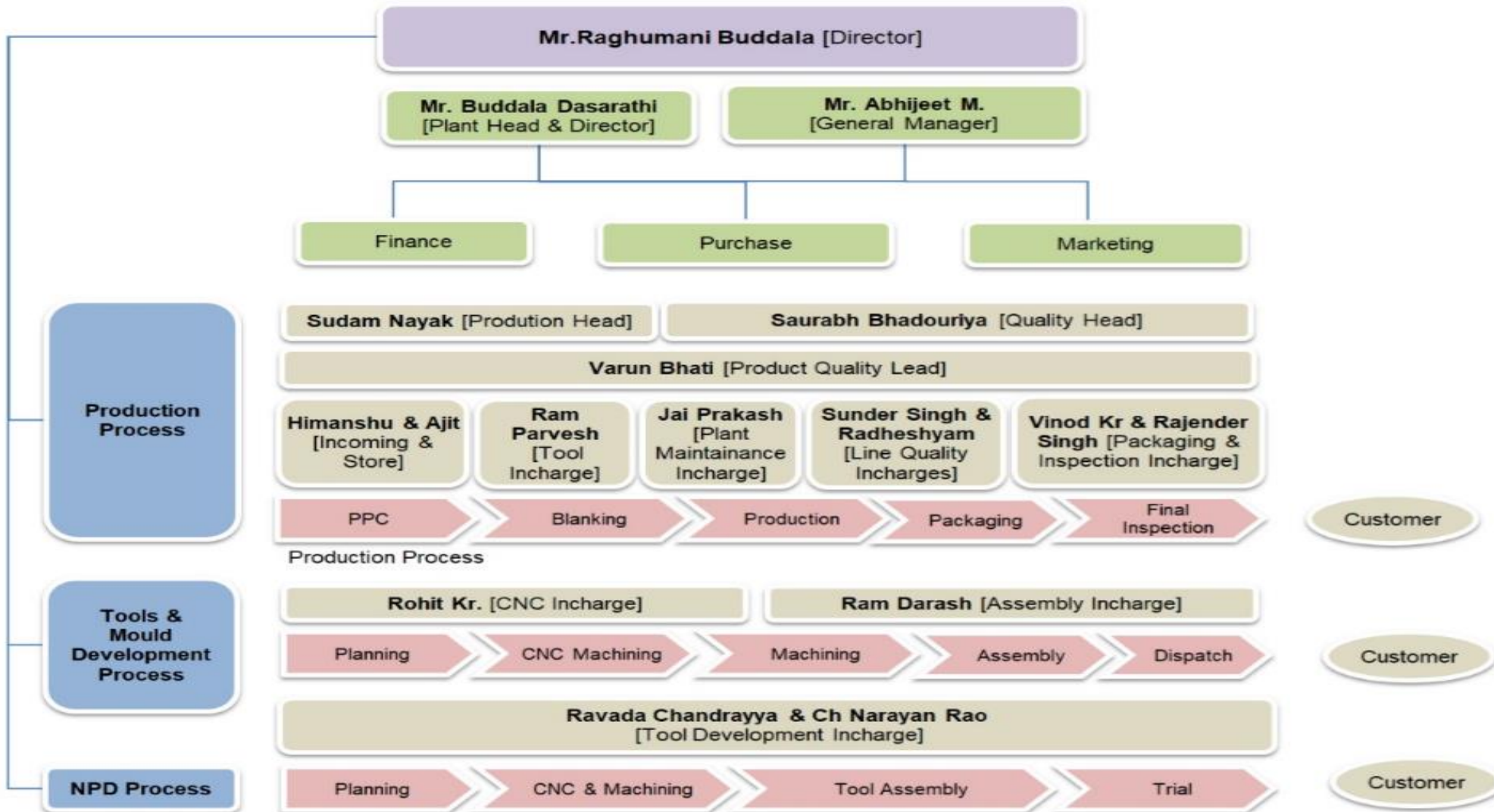

# OUR CUSTOMERS

## CLIENT SATISFACTION



# OUR PRODUCTS

WE THRIVE FOR QUALITY

**Brake Pad Backplates**



**Brake Shoe Levers**



**Brake Shoe**



# OUR PRODUCTS

WE THRIVE FOR QUALITY

Special Washers

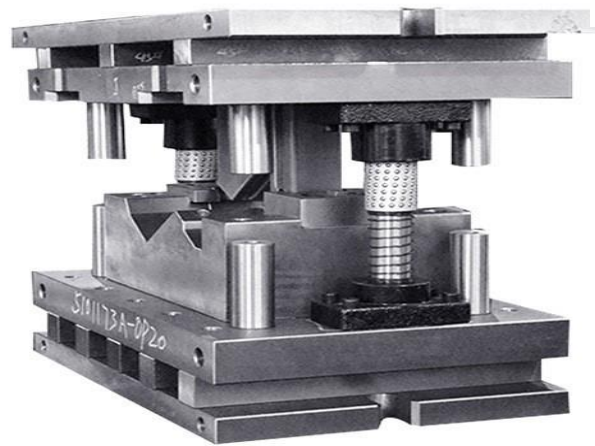

Sheet Metal Stamping Tool

Sheet Metal Auto Components





# OUR PRODUCTS

WE THRIVE FOR QUALITY

**Brake Pad Molding Wanda Tool**



**DT Molding Tool**

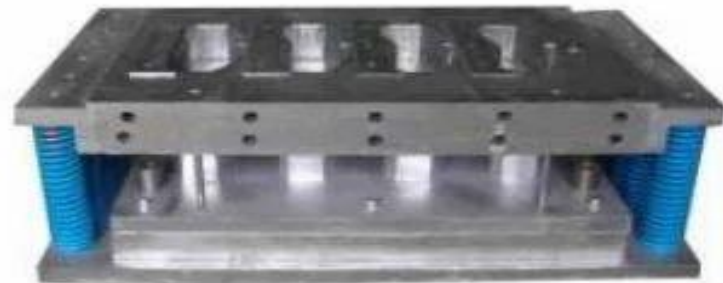

**CV Pad Molding Tool**



**Brake Lining Molding Tool**



# OUR STANDARDS

## QUALITY IS THE BEST BUSINESS PLAN

Provide complete customer satisfaction by offering a wide range of premium quality products at competitive prices.

### Wide Range & Competitive

The company has shown tremendous growth potential – a result of maintaining the most quality standards and delivering products at low cost.



# OUR QUALITY

## CONTINUAL & HORIZONTAL IMPROVEMENT

The company has adopted ISO 9001 quality management systems and also working towards upgrading to IATF 16949. With progressive management techniques, the company ensures that your most demanding specifications are met and deadlines adhered to.

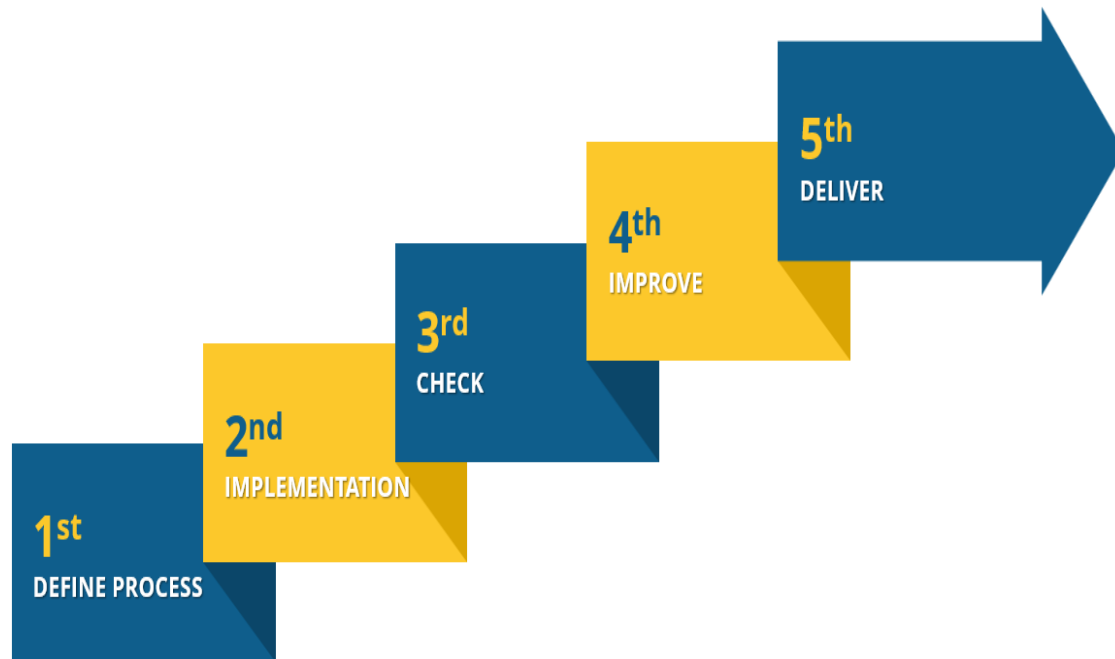

# OUR INFRASTRUCTURE

## WE DO THINGS BETTER

The company have manufacturing unit with more than 3700 Sq. Mtr. Area fully connected to State and National Highways situated in prime industrial location of Sahibabad, Ghaziabad, Uttar Pradesh (National Capital Region). The facility comprises of high-end production machines and tool manufacturing division. The plant have the benefits of qualified and experienced technical supervisors and a motivated work force. A 30 year old track record of product reliability have made **SKV Automotive Pvt Ltd** a name people trust.



# OUR MACHINERY

EQUIPPED MODERN PRODUCTION FACILITY



**CNC WIRECUT MACHINES**



**POWER PRESS MACHINES  
[10 TONNE -150 TONNE CAPACITY]**



**VERTICAL MILLING CENTRE**

# OUR MACHINERY

## EQUIPPED MODERN PRODUCTION FACILITY



**DEBURRING MACHINES**



**PROJECTION WELDING MACHINE**



**SPM DRILLING MACHINE**

# OUR MACHINERY

## EQUIPPED MODERN PRODUCTION FACILITY



**LATHE MACHINE**



**MILLING MACHINES**



**SURFACE GRINDING FACILITY**



# CONTACT US

## **Works & Corporate Office :**

**E-12, Site IV Industrial Area, Sahibabad, Ghaziabad, Uttar Pradesh -201010**

**Email : [info@skvauto.com](mailto:info@skvauto.com)**

## **CONTACT:**

**(+0120)-4091339**

**(+91)-9810707779**

**(+91)-9717225949**

Follow us on

